

Assembly Guide

WaterUps® Oasis 1240 Wicking Bed

15070WOOD

Before you start

Watch the full assembly guide video on our YouTube page. You can go to it using the button or the QR code below.

[Assembly Guide video](#) 



Reservoir liner assembly guide

You can download a copy of the WaterUps® 1680 Reservoir Liner Insert assembly guide by using the button or the QR code below.

[Reservoir liner](#) 



WaterUps® Getting Started page

Our Getting Started page contains lots of helpful information. You can go to it using the link or the QR code below.

[Getting Started page](#) 



Contents

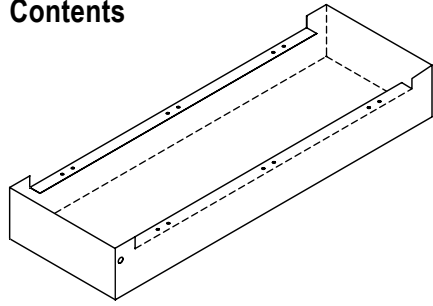

1 x WaterUps® 1240 Reservoir Liner

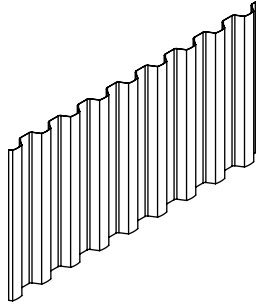

2 x Long Wall Panels

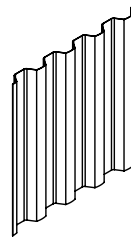

2 x Short Wall Panels

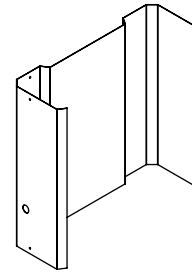

1 x End Panel with hole for the overflow pipe

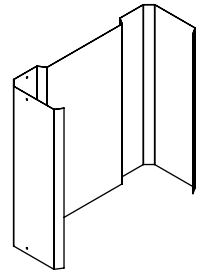

1 x End Panel

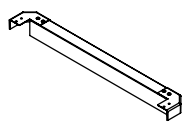

4 x End Rails

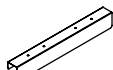

4 x Connector Rails

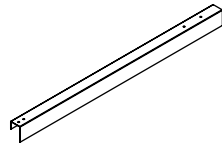

8 x Side Rails



1 x bag of screws

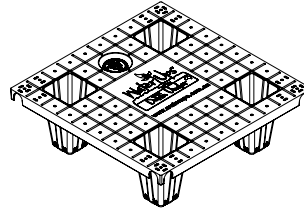

3x WaterUps® Wicking Cells



1 x Inlet Pipe and Cap

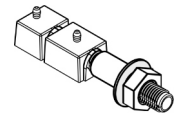

1 x Overflow Pipe & spacer

You will need



Approximately 2 square metres of level ground to build on.



No. 2 Phillips head screwdriver.



A sharp knife.



Approximately 51 litres of water.



1 x 6 litre bag of Perlite.



6 x 25 litre bags of good quality soil or potting mix.

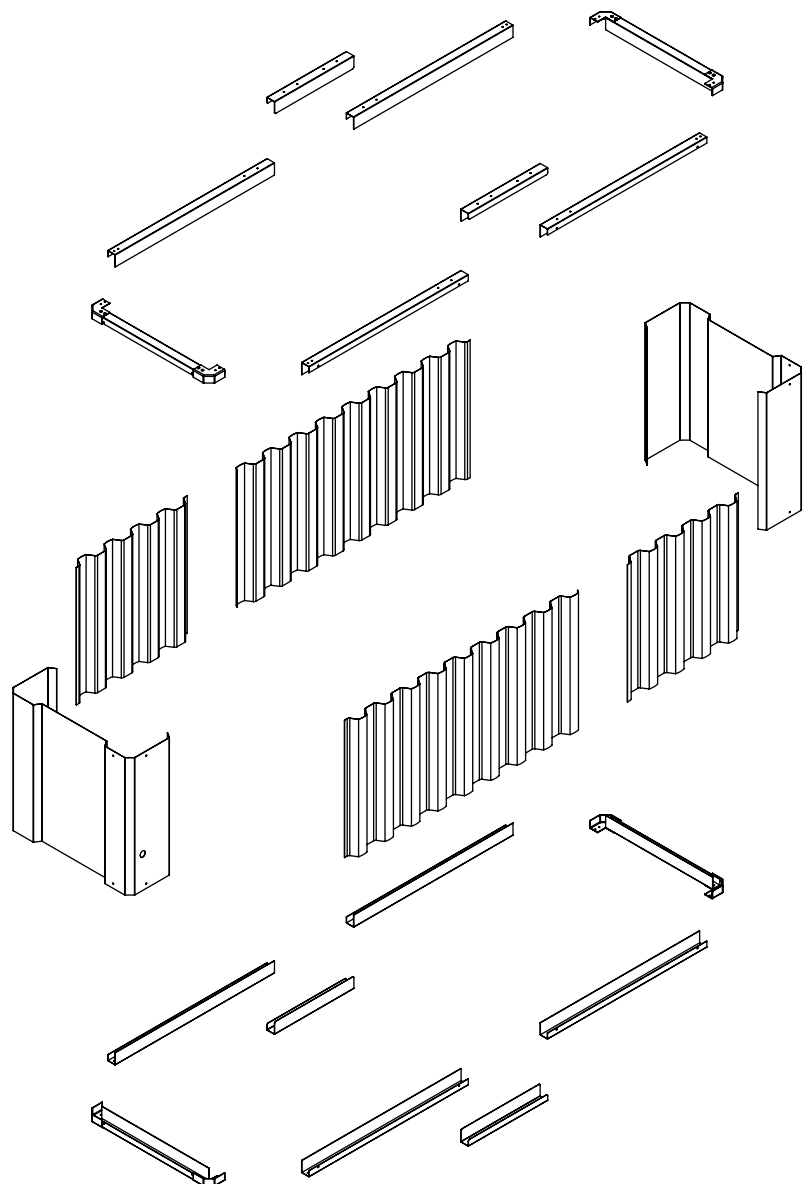

1. Assembling the Oasis 1240 metal bed frame.

Open the box and lay the contents out near the area you will be assembling your wicking bed. Remove any protective film from the pieces as you lay them out. Place the screws in a small container or bowl so as not to lose them.

Join 2 end rails with corner brackets using the long side rails and insert screws to form the base of the bed frame.

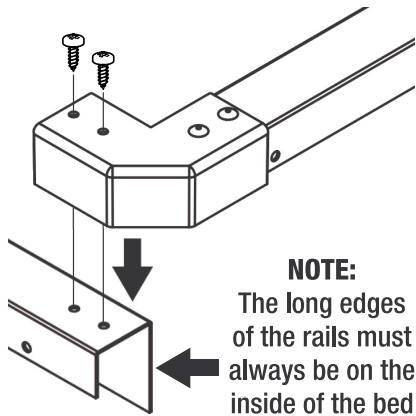

Now locate the end section with the hole for the overflow pipe and insert it into the rail, with the hole for the overflow pipe positioned closest to the rail. Align the screw hole in the end section and the matching hole in the rail and insert screw to secure.

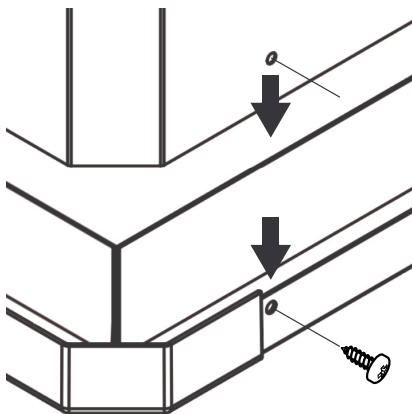

Repeat for the other end section.

Add 1 short and 1 long wall panel to each side of the bed.

Attach the remaining 2 x long side rails to the remaining end rail and insert screws.

Carefully push the end rail into position on the end section and start to push the long side rails onto the wall panels.

Note: this should be a reasonably tight fit. Be careful with any sharp edges.

Once in position screw the top rails to the end panel as you did with the bottom rail.

Now add the remaining end rail and screw into position.

2. Fitting the WaterUps® Reservoir Liner Insert into the bed.

Refer to the WaterUps® 1240 Reservoir Liner Insert assembly guide for how to install the reservoir liner. You can access it by using the link or QR code on page 1.

Before placing the reservoir liner in the base of the bed ensure that the base is level and compacted and free from any sharp objects such as stones.

Place the reservoir liner in the base so that it sits inside the bottom railing, making sure that the hole in the liner for the overflow pipe lines up with the hole in the bed wall.

3. Adding the WaterUps® Cells plus the inlet and overflow pipes.

Place a WaterUps® cell in the base of the liner near the overflow hole to work out the correct position to attach the overflow pipe to the cell.

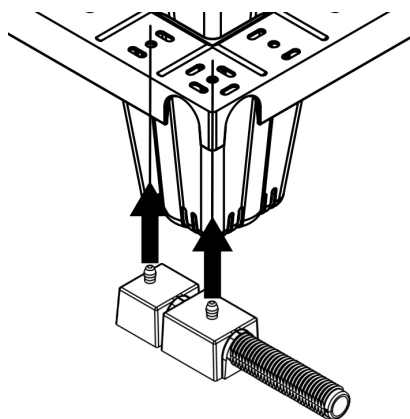

After attaching the overflow pipe and clicking it into position, add the rubber washer to the overflow pipe and push in until it abuts the liner.

Now carefully place the cell with the overflow pipe in the base of the liner positioning it so that the thread of the overflow pipe protrudes from the external wall of the bed frame. Slide on the white spacer pipe and push it through the hole in the steel frame until it abuts the wall of the reservoir liner. Now screw on the nut and secure tightly in position.

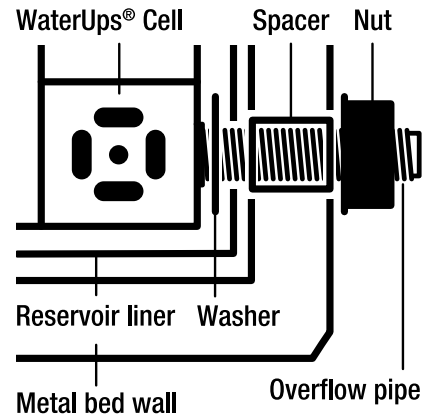

To fit the WaterUps® Inlet Pipe you must first cut a hole in the top of one of the WaterUps® Cells.

Using a sharp knife cut along the circular groove around the type on the top of the WaterUps® Cell as shown in the image at the top of page 4.

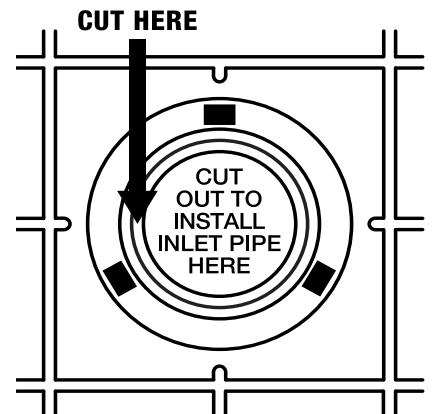

The three tabs on the bottom of the water inlet pipe must lock into the three holes in the top of the WaterUps® Cell. Apply some pressure to the inlet pipe as you insert it, until it clicks into place in the WaterUps® Cell.

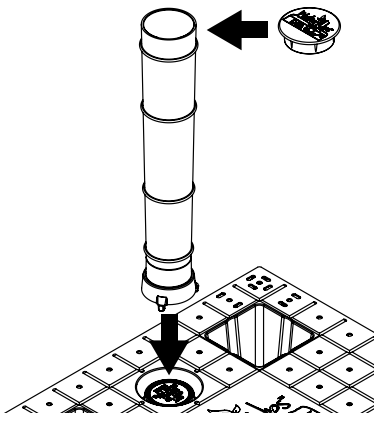

Place all remaining WaterUps® cells in position and fold down the flaps on the top of the reservoir line. These can be secured in position with either cable ties or WaterUps® joiners or simply left folded over.

4. Adding perlite to the feet of the WaterUps® Cell.

Adding Perlite to the 'wicks' will improve airflow through to the soil. Both fine and medium grain perlite work effectively for this purpose.

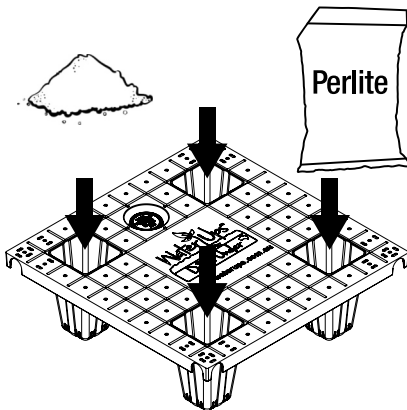

The wicks, which are the 4 feet at the base of each cell, should all be filled with perlite.

You will need 6 litres of Perlite for your Oasis 1240 Wicking Bed.

5. Add potting mix or soil to the wicking bed.

You will now need 6 x 25 litre bags of good quality potting mix or potting soil to fill the Oasis 1240 Wicking Bed.

For more information please refer to our *Soil Considerations Guide* which you will find on our Getting Started page. You can go to it using the link or QR code at the bottom of page 1.

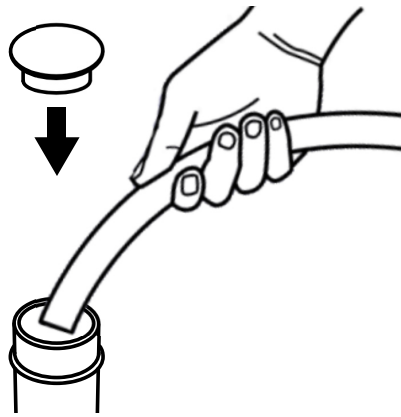

6. Watering your wicking bed.

To water your bed simply insert a garden hose into the inlet pipe and fill the water reservoir until water starts flowing out of the overflow pipe. Replace the cap when done.

The water reservoir of your bed will hold 52.8 litres of water. How often you need to refill the reservoir will depend on what plants you are growing, the time of year, and the amount of natural rainfall that you receive. However, in our experience, periods of up to four weeks are achievable before you will need to refill your wicking bed.

It is recommended that you allow the water level in the bed to go down to at least 1/4 full before refilling. This will assist soil aeration.

To check how much water is in the reservoir simply use a dipstick or set up a moisture sensor system.

Contact Us

Sales

Email: sales@waterups.com.au

Phone: 1300 205 550

General Enquiries

Email: info@waterups.com.au

Account Enquiries

Email: accounts@waterups.com.au

The WaterUps® website is owned and operated by WaterWix Pty Ltd – ABN 58 166 973 011.

The information contained in this document is provided as is and without any warranties of any kind, whether expressed or implied. Users are advised to make their own determination as to the suitability of this information

in relation to their particular purpose or specific circumstances. No responsibility can be accepted by WaterUps®, WaterWix Pty Ltd, or its staff for any loss resulting from any action taken or reliance made by you on any information contained in this document.

Copyright © 2022 WaterWix Pty Ltd. All rights reserved. WaterUps, the WaterUps Logo and Wicking our World are registered trademarks of WaterWix Pty Ltd.

Published: 5 April 2022